



Laser-based Gas Monitoring System

LEADERS IN GAS DETECTION

Since 1977

LMS Remote

System Description

LMS-Remote is a stationary natural gas leak detection system for remote monitoring of elevated methane gas concentrations in ambient air. It is specifically designed for the constant scanning and monitoring of mission-critical areas such as compressor stations, gas tanks, storage facilities, tank farms, gas stations and LNG Terminals.

The LMS-Remote System is based on new technology for detecting natural gas leaks. The system utilizes a post diode laser at a wavelength of 1.65 μm allowing the system to detect traced amount of gas concentrations. The optical unit is installed on a pan tilt platform and is designed to scan remote pre-set areas or preset target points. A laser beam is emitted from the sensor and strikes a remote object. The system analyses the laser light back scatter to determine how much, if any of the laser energy was absorbed by methane along the laser-light path. A unique detection algorithm allows for real-time measurement of the methane concentration above atmospheric levels. A video camera is installed in the detector helps the operator in determining the gas cloud location online.



The system consists of three components:

The optical unit is mounted on a new generation of servo driven pan/tilt head installed at an elevated location such as a facility mast lighting. This components contains the laser, receiving system, HD video camera, control board, heater, reference cell and signal processing board.

The electronic unit includes special instrumentations boxes with communication equipment and DC converter. The operator PC constantly monitors detection alarms, system control, data, video storage and historical data analysis. The system continually records data including coordinates of leaks, sizes of leaks and additional information about system operations. A report about system operations, leak sizes and locations can be made using the included data-processing software.



Head Office:

Unit 1 / 3 Deakin Street
(PO Box 5904)
Brendale QLD 4500 Australia
Ph: +61 (0) 7 3481 9000

Perth Office:

Unit 5 / 30 Enterprise Crescent
Malaga WA 6090 Australia
Ph: +61 (0) 8 6184 7840
sales@controlequipment.com.au

Representatives/Offices in:

Sydney Melbourne
Hobart Adelaide
Auckland Wellington
www.controlequipment.com.au

User-Friendly Software

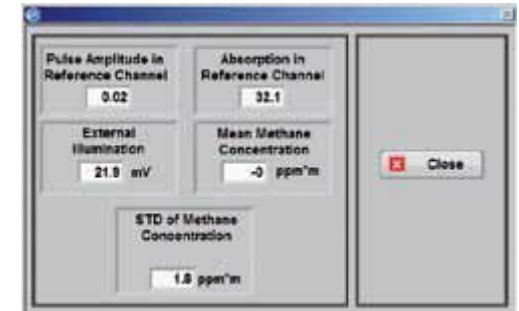
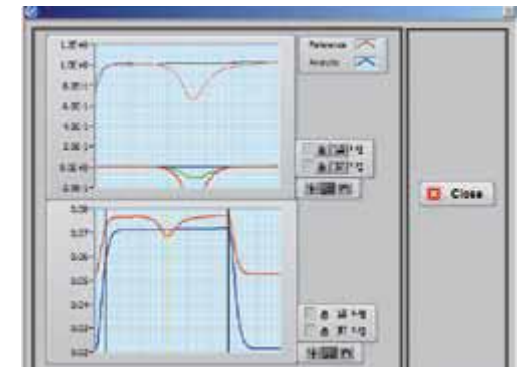

Benefit of LMS-Remote

- Fully automatic. The system can be programmed to scan specific areas.
- Detects gas leaks faster than conventional methods. (detection speed 0.1 sec)
- The LMS-Remote system operates 24 / 7 / 365.
- The measured methane concentration is displayed in real time and stored for post analysis.
- Sensitive only to methane. No false detections.
- Panoramic scanning capabilities, no blind zones.
- Can be fully integrated with existing facilities.
- User-friendly software.
- Complete monitoring include database of operation actions. Archive data for the entire period of operation.
- Explosion-proof certificate.
- Calibration and self-check during operation.

The LMS-Remote System operates 24 / 7 / 365 to ensure the safety of your facility.

Items	Specifications
Maximum measurement distance	150 m (stationary version retroreflector up to 1 km)
Range of movement	Azimuth n x 360° Elevation - 90 to + 30
Measurement time	0.02 sec, 0.1 sec (simultaneously)
Sensitivity of 0.2 sec measurement time	
from distance 50 m	25 - 20,000 ppm*m
from distance 100 m	100 - 20,000 ppm*m
from distance 150 m	225 - 20,000 ppm*m
Laser wavelength	1.65 μm
Laser power	25 mW
Power supply	12 V 6 A and 24 V 6 A
Total weight	45 kg
Environment protection	IP67
Operating temperature range	- 50° C to +40° C
Video camera	Full 1920 x 1080/30p High Definition; 200 x zoom ratio (20 x zoom/10 x digital);with analyzing / post-processing software
Relative measurement accuracy	1% (but < threshold sensitivity)
Selectivity to other gases	< 10 Exp 4
Service intervals	one year
Explosion proof	The LMS-Remote is NANIO certified

Principle of remote detection

LMS-Remote is based on the utilization of laser absorption spectrophotometer of methane gas for gas measurement.

The system detects natural gas leaks by emitting a laser at particular wavelength and analyzing the light reflection from an object to determine how much was absorbed by the methane in the natural gas.

The measured gas volume is expressed by methane column density (ppm - m): methane density (ppm) multiplied by thickness (m).

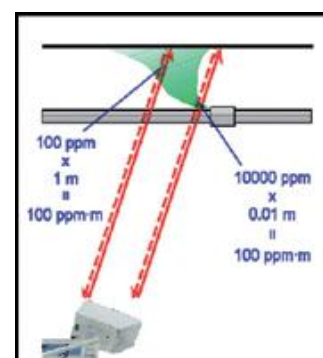

Explosion-proof certified detector

The LMS-Remote is TR TS approved applied for operation in hazardous areas Zone 2. LMS-Remote System can be fully integrated into existing structures including interaction with other systems such as fire protection systems, gas emission control systems



Head Office:

Unit 1 / 3 Deakin Street
(PO Box 5904)
Brendale QLD 4500 Australia
Ph: +61 (0) 7 3481 9000

Perth Office:

Unit 5 / 30 Enterprise Crescent
Malaga WA 6090 Australia
Ph: +61 (0) 8 6184 7840
sales@controlequipment.com.au

Representatives/Offices in:

Sydney Melbourne
Hobart Adelaide
Auckland Wellington
www.controlequipment.com.au